

MULTITECH G, best performing spacer World Wide.

This unique metal free spacer provides excellent thermal performance combined with excellent tightness for gas and humidity.



Standard length
5,000 & 6,000 mm
± 10 mm

DIMENSIONS

Sizes	B [mm] +/- 0.15	H [mm] +/- 0.1
MULTITECH G 8	7.50	6.5
MULTITECH G 10	9.50	6.5
MULTITECH G 12	11.50	6.5
MULTITECH G 13	12.50	6.5
MULTITECH G 14	13.50	6.5
MULTITECH G 15	14.50	6.5
MULTITECH G 16	15.50	6.5
MULTITECH G 18	17.50	6.5
MULTITECH G 20	19.50	6.5
MULTITECH G 22	21.50	6.5
MULTITECH G 24	23.50	6.5
MULTITECH G 27	26.50	6.5

MATERIALS

SAN PLAST

The wall thickness is standard 0.90 mm
+0.25/-0.05 mm

FOIL

Foil thickness is standard 40-45 µm

ACCESSORIES

Connectors



Plastic/Nylon



Steel

Corner



Plastic/Nylon



Butyle

Other accessories as flexible corners etc. are also available

COLORS

WHITE

≈ RAL 9016



LIGHT GREY

≈ RAL 7035



BLACK

≈ RAL 9004



LIGHT BROWN

≈ RAL 8003



DARK BROWN

≈ RAL 8016



EN1279 Normative test references and other methods



Pull force

Depends on chosen connector



Rectitude from production

Sideways max. 5 mm/m
Up/down max. 10 mm/m

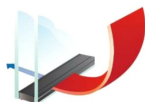

Two box model characteristic value

IFT WA-17/1
 $\lambda_{eq,2B} = 0.14 \text{ W/mK}$



Perforation holes size

Checked with airflow
Allowed humidity uptake 1-5wt% pr. 24 hours



Compression data (16 mm spacer)

Max 40 N/cm standard pressure



Volatile elements / Fogging

EN 1279
 $M_v < 0.3\%$ / No fogging 60°C and 75°C



Thermal linear expansion

$T_{\alpha, \text{foil}} 16 \text{ mm spacer} = 1.83 \times 10^{-5} \text{ 1/K}$
 $T_{\alpha, \text{poly}} 16 \text{ mm spacer} = 2.01 \times 10^{-5} \text{ 1/K}$

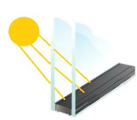

UV stability

EN ISO 4892-2/A (CSTB test)
3,000 hours of radiation with no significant color change.

QUALITY ASPECTS

Quality management

EN ISO 9001 for quality

Tests of the product

Processes and routines are established to secure the quality of the delivered material. During production the spacers are continuously monitored through systematic and random checks. Data will be available for a period of 10 years.

Full filing external demands according to:

- EN 1279
- Passive House Component Class phA for arctic climate
- RAL gütezeichen
- DTA for use in France under Ceval

CUSTOMER FOCUS AND WARRANTY

On all spacers we offer a 5 years' product warranty. The warranty covers free exchange of spacers in case of a defect. The warranty does not cover any other cost than the mere exchange of the defect spacers, and the warranty expressly does not cover installation of the spacers. The spacers must have been stored, installed and used according to present norms and technical standards. Special solutions and **usage that are not standardized** will need prior approval in writing from us in order to be covered. Related to temperature standardized condition for IG is $-30^{\circ}\text{C}/+70^{\circ}\text{C}$.

Storage and use

To secure the performance of the spacers, the stock conditions must be acceptable. Broken packaging, humidity and variation in temperature will have an effect on the spacer in general. Make sure the spacer is conditioned at room temperature before use.

Preferred conditions will be temperatures over 15°C and humidity RH of minimum 45%. Avoid having an environment with high concentration of dust.

General handling and attention according to safety data sheet for the spacer. Use gloves when handling the spacer/frames and make sure there is exhausting when cutting the spacer.

System performance

The user (the IG producer) must secure the whole system consisting of spacer, connector/corner key, bending machine, desiccant, butyl and sealant works well together in the chosen setup. Focus on compatibility, adhesion, dust and corner quality.

After handling and transport of the frames, it's important to check if the connector/corner keys are still in the correct position, if not there is a significant risk for desiccant dust inside the IG unit. Foam behind the connector/corner can be used to avoid such problems.

Cleaning the plastic surface

If for some reason, the plastic surface is defiled by dust from other materials it can be cleaned again by use of water or air. Dust can easily be removed with antistatic loaded compressed air or a moist cloth. Solvent based cleaners are not recommended, but if used, it is recommended to test influence on products.

It is recommended to investigate and control all the specific points above.

ADDITIONAL SPECIFICATIONS AND INSTRUCTIONS

Packaging, volumes and options

Packaging Sizes	Quantity meter cardboard boxes		Quantity meter stillages		
	5 meters	6 meters	NM type (5 meters)	NM type (6 meters)	ZM type (6 meters)
8	960	1,152			19,584
10	800	960	10,240	12,288	19,584
12	640	768	8,640	10,368	16,128
13	560	672	7,680	9,216	14,976
14	560	672	7,680	9,216	14,976
15	480	576	7,040	8,448	13,248
16	480	576	6,720	8,064	13,248
18	400	480	6,080	7,296	12,096
20	400	480	5,440	6,528	10,944
22	320	384	4,480	5,376	8,640
24	320	384	4,480	5,376	7,488
27	240		3,840		

Packaging Sizes	Quantity pcs. / box		
	Steel (DP*)	Plastic/Nylon (DP*)	Plastic/Nylon corner
8	2,500	2,000	2,000
10	2,500	2,000	2,000
12	2,500	2,000	2,000
13		2,000	5,000
14	2,500	2,000	2,000
15	2,500	2,000	2,000
16	2,500	2,000	2,000
18	2,500	2,000	2,000
20	2,500	2,000	2,000
22	2,500		2,000
24	2,500		2,000
27			1,400

Sizes	Content [g/m] +/-10% Desiccant 0.5-0.9 mm grain	Connector		Corner
		Steel (DP*)	Plastic/Nylon (DP*)	Plastic/Nylon Corner
8	18	✓	✓	✓
10	25	✓	✓	✓
12	31	✓	✓	✓
13	34		✓	✓
14	38	✓	✓	✓
15	42	✓	✓	✓
16	45	✓	✓	✓
18	52	✓	✓	✓
20	58	✓	✓	✓
22	65	✓		✓
24	72	✓		✓
27	82			✓

*DP = Desiccant passage

All connectors are basically U-shaped and with passage for flow of desiccant during after filling.
Note that there will be a difference in pull force between preinserted- and direct inserted connectors.

Energy labeling

For thermal calculations, we recommend using *the two box model* due to the extremely thin dimensions for the foil

Materials	λ [W/mK]
Secondary sealing	0.40
Spacer box	0.14

Thermal data

An overview of thermal data with different constructions. These data are calculated by Bauwerk according to IFT guideline WA-08/3.

Frame: Aluminum profile – $U_f = 1.6$ W/m²K

Glass	Double IG - $U_g = 1.1$ W/m ² K (4-16-4)			Tripple IG - $U_g = 0.7$ W/m ² K (4-12-4-12-4)		
	Ψ_g [W/mK]	$\Theta_{si(-10/-5^\circ C)}$	U_w [W/m ² K]	Ψ_g [W/mK]	$\Theta_{si(-10/-5^\circ C)}$	U_w [W/m ² K]
CHROMATECH	0.068	8.4 / 10.3	1.439	0.066	10.6 / 12.2	1.174
CHROMATECH ultra S	0.050	9.8 / 11.5	1.395	0.046	12.0 / 13.3	1.126
THERMIX TX Pro	0.049	9.8 / 11.5	1.393	0.044	12.0 / 13.3	1.121
CHROMATECH ultra F&F1	0.048	9.9 / 11.6	1.390	0.043	12.1 / 13.4	1.118
MULTITECH-P G	0.039	10.6 / 12.2	1.369	0.034	12.7 / 13.9	1.097
MULTITECH G	0.036	10.8 / 12.4	1.362	0.031	12.9 / 14.1	1.090

Frame: PVC profile – $U_f = 1.2$ W/m²K

Glass	Double IG - $U_g = 1.1$ W/m ² K (4-16-4)			Tripple IG - $U_g = 0.7$ W/m ² K (4-12-4-12-4)		
	Ψ_g [W/mK]	$\Theta_{si(-10/-5^\circ C)}$	U_w [W/m ² K]	Ψ_g [W/mK]	$\Theta_{si(-10/-5^\circ C)}$	U_w [W/m ² K]
CHROMATECH	0.051	8.3 / 10.3	1.257	0.050	9.9 / 11.6	0.982
CHROMATECH ultra S	0.040	9.5 / 11.3	1.230	0.038	11.1 / 12.6	0.953
THERMIX TX Pro	0.040	9.5 / 11.3	1.230	0.038	11.1 / 12.6	0.953
CHROMATECH ultra F&F1	0.039	9.6 / 11.3	1.228	0.037	11.2 / 12.7	0.950
MULTITECH-P G	0.034	10.2 / 11.9	1.216	0.032	11.8 / 13.1	0.938
MULTITECH G	0.031	10.5 / 12.1	1.218	0.029	12.1 / 13.4	0.931

Frame: Wood profile – $U_f = 1.4$ W/m²K

Glass	Double IG - $U_g = 1.1$ W/m ² K (4-16-4)			Tripple IG - $U_g = 0.7$ W/m ² K (4-12-4-12-4)		
	Ψ_g [W/mK]	$\Theta_{si(-10/-5^\circ C)}$	U_w [W/m ² K]	Ψ_g [W/mK]	$\Theta_{si(-10/-5^\circ C)}$	U_w [W/m ² K]
CHROMATECH	0.053	7.3 / 9.4	1.322	0.054	9.6 / 11.3	1.045
CHROMATECH ultra S	0.041	8.6 / 10.5	1.293	0.040	11.0 / 12.5	1.010
THERMIX TX Pro	0.040	8.7 / 10.6	1.290	0.039	11.0 / 12.5	1.008
CHROMATECH ultra F&F1	0.039	8.8 / 10.7	1.288	0.038	11.2 / 12.7	1.005
MULTITECH-P G	0.033	9.5 / 11.2	1.273	0.031	11.8 / 13.2	0.988
MULTITECH G	0.031	9.7 / 11.4	1.268	0.029	12.1 / 13.4	0.983

Frame: Wood aluminum profile – $U_f = 1.4$ W/m²K

Glass	Double IG - $U_g = 1.1$ W/m ² K (4-16-4)			Tripple IG - $U_g = 0.7$ W/m ² K (4-12-4-12-4)		
	Ψ_g [W/mK]	$\Theta_{si(-10/-5^\circ C)}$	U_w [W/m ² K]	Ψ_g [W/mK]	$\Theta_{si(-10/-5^\circ C)}$	U_w [W/m ² K]
CHROMATECH	0.059	6.1 / 8.4	1.342	0.060	8.7 / 10.6	1.075
CHROMATECH ultra S	0.045	7.6 / 9.7	1.308	0.043	10.2 / 11.8	1.033
THERMIX TX Pro	0.043	7.6 / 9.7	1.303	0.042	10.3 / 11.9	1.031
CHROMATECH ultra F&F1	0.043	7.8 / 9.8	1.303	0.041	10.4 / 12.0	1.028
MULTITECH-P G	0.036	8.5 / 10.4	1.266	0.034	11.1 / 12.6	1.011
MULTITECH G	0.033	8.8 / 10.7	1.279	0.031	11.4 / 12.8	1.004

Θ Internal glass temperature

To calculate with other U-values for glass please refer to our homepage where a calculator can be found (<https://apps.sommer-informatik.com/winuw/rolltech/>). Is also available as an app "WinUw ROLLTECH". Access it by Apple store or on Google play.

Adhesion check

According to EN1279-6 D.2 the following test must be done in order to check mixing and secure the adhesion between spacer and sealant. A pull of 0.3 MPa shall be applied for 10 minutes. No adhesive breakage is allowed (slip to surface).

The following is a guide to achieve the correct results for our spacers. The sealant shall cover 20 mm of the spacer back as shown on the drawing. No precleaning of spacer is allowed. It is important to secure a proper contact between sealant and spacer back. The support from the test machine shall be as close as possible to the sealant and direct to the spacer back as illustrated.

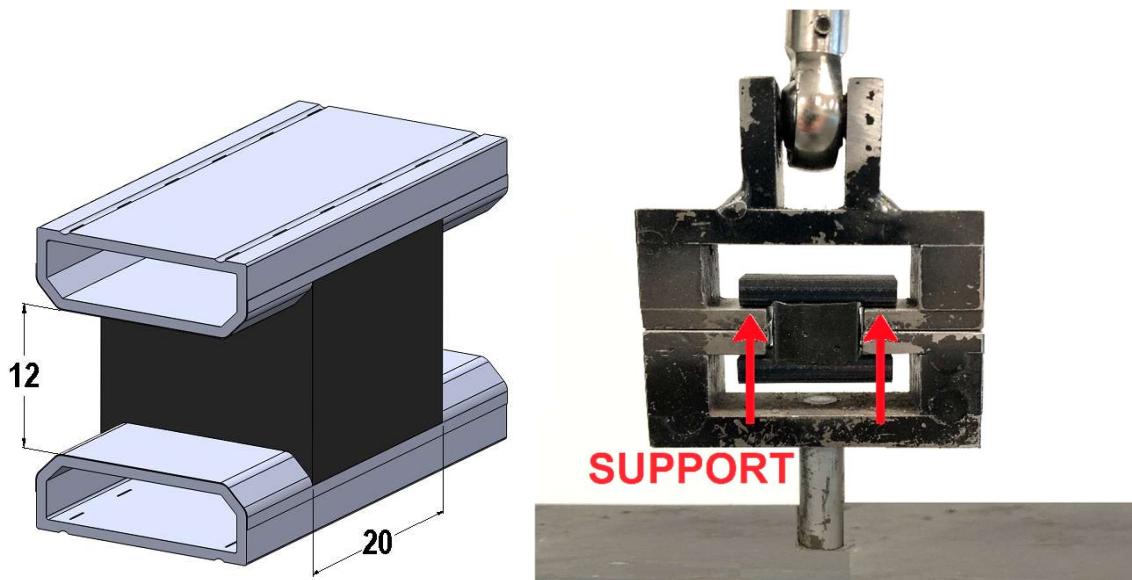

Ask actual sealant supplier for the conditions required during curing. Here some general guidelines:

- For PS curing at 20°C over a period of 24 to 48 hours is normally enough.
- For PU curing at 20°C can take much longer depending on the PU version. 28 days or more is quite normal. Ask sealant supplier for guidelines, it might be possible to accelerate the curing at a higher temperature.

Check the samples for type of breakage. Adhesive breakage is not allowed, and if seen analyzing is needed. Sources to failure: Wrong mix of sealant (A+B), insufficient application, contamination, or deformation of spacers.

Bending

- Use bending tools recommended by bending machine supplier
- Adjust side pressure until correct corner width is obtained (max +0.3 mm)
- Over bending due to resilience is to be adjusted for perfect 90° corners
- Room temperature during processing > 15°C

For further bending instructions, contact your bending machine supplier. Pay careful attention to our ***Instruction for processing.***